

HOT SHOTS & COOL NOTES

In this issue

Letter from the President	1
ME on IBA	2
Equipment Highlights at IBA ...	3
Shawna on Mixing	6

Stay Tuned for articles on ...

- When to Automate
an Artisan Bakery
- Calculating ROI

Kemper Bakery Systems
tel 203.929.6530, ext 318

www.kemperusa.com
info@kemperusa.com



Innovators Think Process



At WP Bakery Group, our focus is machines. From our popular Quadro Round and Crustica bread systems to our fully automated sheeting lines, our systems are designed to handle true artisan style doughs—doughs with high absorption rates and long bulk fermentation times.

These systems are designed and tested to provide **consistent high quality** product that customers demand and produce the **volume** to help bakeries remain profitable.

At the 2006 IBA show, our factories—Werner & Pfleiderer, WP Haton, and Kemper—rolled out their latest innovations and time-tested machines for the most important and largest bakery show in the world. And once again, for the third consecutive time, WP Bakery Group won two of the **INNOVATION** awards.

WP Bakery Group equipment provides solutions to bakeries worldwide and Kemper Bakery Systems is your local link to the best in bakery technology.

For those of you who missed this giant show, we are bringing a piece of it to you inside these pages. Don't miss Michael Eggebrecht's insider view to IBA 2006 on page 2.

Patricia Kennedy,
President
Kemper Bakery Systems

WP BAKERYGROUP

Today, we are producing a new generation of machines and systems. What sets them apart?

- Excellent handling of dough
- High absorption rates (up to 80%)
- Long bulk fermentation time
- Consistent high quality
- Low energy consumption
- Highest standards for hygiene
- Service, training and maintenance

We are **passionate** about bread.



ME



IBA 2006

Thoughts from the Inside

2006 marked my first trip to the International Bakers Association Exposition (IBA) that is held every three years in Germany. I have attended many other bakery expositions in the past both here in the US and abroad. If I had to use a couple adjectives to sum up the IBA

you did not know needed to be done. You see machines like fixed bowl mixers, for example, range in price from \$650 to over \$100,000. Yes I said \$650 USD! One thing is for sure: if you manufacture bakery equipment, you had better be at IBA.

After a few passes down the aisles, you begin to notice the difference in the professionalism between companies, and you get a good feel for who are the powerhouses and leaders in the industry. You get a chance to look at equipment almost side by side and notice the differences between the individual companies. I saw Conical Rounders that looked like it had my gutter attached to the cone. I was looking for the trap door that kept the hamsters. I walked away thinking it must be underneath, out of view.

I only point out these things

that leads the way in new developments and that offers solutions. The WP Group again won the IBA award for new technology, making it the third win in the past three IBA shows. What may seem far fetched today will, in fact, become the norm for equipment in the future and WP is developing it.

My role during the show was different than everyone else's at our booth. The first day I wore a suit and tried to help on the sales side of things. After that first day I realized I was out of my comfort zone and decided to try a different approach. From then on I showed up in traditional baker's whites and started work at 6 a.m. I wanted to run the machines myself and use the opportunity to learn. I grabbed a few of my fellow friends that were visiting and probed



Scenes from the WP Bakery Group booth at IBA 2006.

show I would have to say both **"Professional"** and **"Industrial"** come to mind.

Manufacturers from every corner of the globe arrive with massive displays that dwarf our United States expos. With fully automated bread lines and automatic oven loaders going all day long, it is a sight to behold. As you walk the aisles, you see equipment that you did not know even existed doing things that

because for the first time I realize how lucky I am to be working for a company that strives to make the best bakery equipment on earth. I saw first hand the professionalism that my co-workers applied to their careers and how serious everyone at the WP Group takes his/her job.

With many of my mentors and peers from the USA present during the show, I felt proud to be working with a company

them for their opinions about the equipment and what they thought. I got a chance to work with the Master Bakers from the factories and explain to them the rise in quality baking in America.

There were many quality companies at the show and some I am proud to call competitors, but the one thing I did not see was another company that offered complete solutions like the WP Bakery Group. The WP Bakery Group, which



encompasses KEMPER, WERNER PFLEIDERER, and WP HATON, and many other factories and products that we do not offer here in the States, is the largest bakery equipment manufacturer in the world. Each of these individual factories comprise a whole that is unmatched by any other company worldwide, and Kemper Bakery Systems is the United States' direct link to this vast network of possibilities.

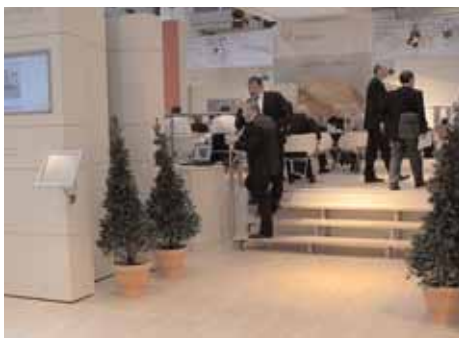

CRUSTICA & MINICRUSTICA

FULLY AUTOMATIC BREAD LINE FOR A VARIETY OF BREAD PRODUCTS



Perfect automated solution for a bakery producing a variety of products from Ciabatta and baguettes to other very soft types of wheat dough with long bulk fermentation times.



QUADRO-ROUND Systems

ROUND, SQUARE AND RUSTIC ROLLS WITHOUT DEGASSING THE DELICATE CRUMB STRUCTURE



This line is ideal for bakeries that want to produce high quality product with high absorption rates and long bulk fermentation times. Artisan bakers love the QUADRO-ROUND system. Ask about our excellent US reference list.

OBER JUNIOR

3-STAR-SERVICE

The **OBER Junior** is a new fully automatic loading robot that will run up to three ovens with a total of 18 decks. It can either be used solely for one oven or as a mobile unit servicing up to three ovens.

The **OBER Junior** is the easiest and quickest way for smaller and medium-sized companies to dispense with the heavy oven work and redistribute labor to other tasks.

CAPACITY

Crosswise movement. . . . 0,5 m/sec
 Lifting. 0,4 m/sec
 Feeding 0,5 m/sec
 Discharging 0,35 m/sec



DEMONSTRATION CENTER

Come and test this new loading technology and the experience the **GREATEST BAKE** on the renowned **Matador** deck oven at our new demonstration center in Hartford, CT.

Call to make an appointment.

203.929.6530 ext. 318



MATADOR

FOR 50 YEARS THE STANDARD FOR EXTRAORDINARY BAKING RESULTS

The **MATADOR's** worldwide success tells its own story and quite frankly sells itself. More than 50,000 of these ovens have been sold worldwide. Owners normally are quality oriented bakers, entrepreneurs who know that only constantly high quality bakery products assure the economic success of a company. Are you a candidate for the **MATADOR** club?

- Zyklotherm heating system
- Greatest temperature flexibility plus two heating temperature zones
- Incredibly fast recovery times
- High temperature increase ability
- Ergonomic work environment
- Optimal formation of crust
- Top production quality



BAGUETTA+

FULLY AUTOMATIC BREAD LINE FOR STRESS FREE PRODUCTS SUCH AS THE BAGUETTE, BRIOCHE, AND STANDARD PAN BREADS



If you produce more than 2500 baguettes/day and have other products that need to be automated then you should take a close look at the **BAGUETTA+**.

PRESIDENT

SPIRAL MIXER WITH REMOVABLE BOWL

Since its introduction at Europain 2005 in Paris, the **PRESIDENT**—the first spiral mixer with a removable bowl—continues to garner accolades for its excellent kneading qualities, solid built, serviceability, and easy cleaning.

The **PRESIDENT** series of mixers—there are five different sizes—can accommodate capacities ranging from 75 kg of flour (160 kg of dough) up to a maximum capacity of 250 kg of flour (400 kg of dough).

All models can be integrated into automatic bowl transport systems.



President 75
75 kg flour
160 kg dough
President 100
100 kg flour
200 kg dough
President 125
125 kg flour
250 kg dough
President 150
150 kg flour
300 kg dough
President 200
200 kg flour
400 kg dough
President 250
250 kg flour
500 kg dough



PowerMixer 75D
75 kg flour
160 kg dough
PowerMixer 150D
150 kg flour
300 kg dough
PowerMixer 320D
320 kg flour
640 kg dough
PowerMixer 150AE
150 kg flour
300 kg dough

POWERMIXER

THE DOUBLE SPIRAL KNEADER

Many bakeries from the medium-sized to larger companies with multiple production facilities prefer the kneading capability of the **POWERMIXER**.

Equipped with a second spiral and designed with the KEMPER 3-zone kneading principle, this double-spiral kneader can produce more dough faster. Dough throughput is more than 3.5 tons per hour in the case of the largest model.

Due to the success of this mixer, Kemper introduced a smaller and larger model. Today three models—75, 150 and 320D—are available. They can be installed as a stand-alone solution or can be integrated into automated systems.

The KEMPER **POWERMIXER** is available with a removable bowl or with bottom discharge.

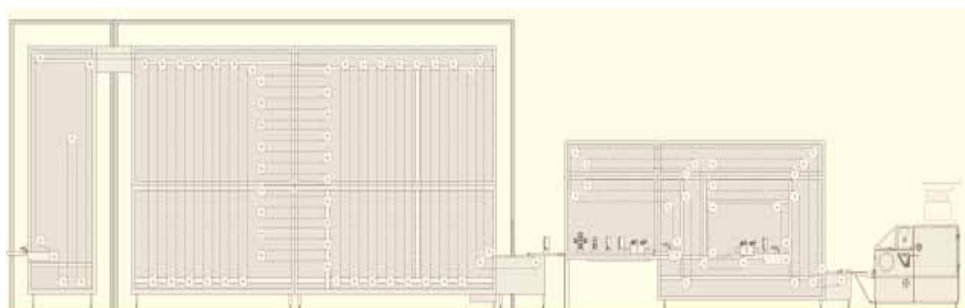

WP KEMPER DONUT & BAGEL WIZARD

A BREAKTHROUGH IN DONUT & BAGEL PRODUCTION

This patented donut & bagel line is also equipped with everything that is necessary for the production of bread rolls. It has the unique ability to produce donuts and bagels out of round molded dough pieces with the same tools and stations. Start minimizing dough waste today.



The Donut and Bagel Wizard claimed one of the top honors in INNOVATION at IBA 2006.

Capacity

- **Water absorption max. 165%**
- **6 – 16 Rows**
- **12,000 – 30,000 pieces/hour**

SHAWNA GOLDFARB



What's New in Mixing

Kemper's newest lines of mixers promise to be the best in the industry.

The SP II mixers are the most demanded brand for bakeries, specifically high quality artisans. Our reference list is impressive and speaks for itself that Kemper is the best Spiral Mixer for the **highest quality dough development**.

The SP II mixers sleek new color and stronger mixing potential is creating much success in today's retail and wholesale bakeries. Our mixers use the **3-Zone Kneading Principle**. This principle uses mixing, resting and an air zone to ensure a high quality mix every time.

Another great feature of the SP II mixers is the **seamless stainless steel bowl and spiral**. The bowl is cast from a single mold. The spiral is also crafted using one solid piece of steel that is wrapped around a mold. Doing this helps to prevent cracking, splitting and warping creating a bowl and spiral that will last for 20 years.

From New York to Hawaii, this line of fixed bowl mixers is consistently being asked for. For this reason, we are bringing in constant stock to keep up with the demand. Kemper is also adding dealers all over the country to help customers with anything they might need.

If you have any questions about our new line, call me anytime!

Kemper's Famous 3-zone Mixing Principle

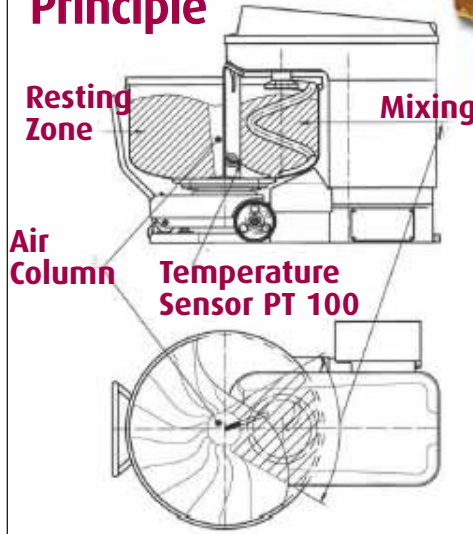

SP 75 II Fixed Bowl Mixer

Capacity (lb)		Oper. Cap. (hp)		Bowl	Dimensions	Weight
Flour	Dough	Spiral	Bowl	dia. (in)	L x W x H (in)	lbs
165	265	3.75 / 10.5	1.5	30	51 x 35 x 67	1235



- Mobile Spiral Mixer for the production of all standard doughs up to an absorption rate of 52%
- Bowl reverse
- Two electro-mechanical timers
- Push button switches, illuminated
- Hand / Automatic switch
- Relay control, operating panel in machine head with timers and selection switches
- Virtually maintenance free due to the use of high quality materials

Spotlight on Mauna Kea Baking

Kemper recently sold a new SP 75 II mixer to Mauna Kea Baking in Honolulu, HI.

Chris Miura, president of Mauna Kea Baking, called me last September looking for a spiral mixer that could do both small and large capacity mixing.

Chris explained how he had used Kemper mixers in the past and had great success with them. He also explained that Kemper mixers are a “standard mixer” in Hawaii and come highly recommended as a “high quality”, “reliable” mixer from other bakers in the area and he saw Kemper mixers even in many of the baking courses he had taken.

Chris liked knowing Kemper had service and parts in the United States. He said many of the other popular brands do not have that capability, which makes it very difficult should any questions arise.

Knowing the type of production that Chris needed, I recommended the **SP 75**

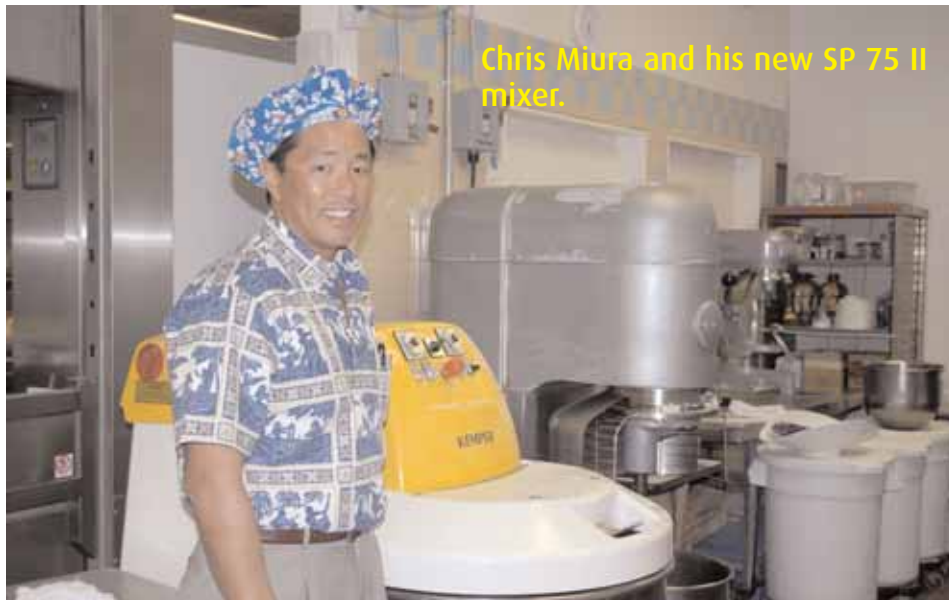

Chris Miura and his new SP 75 II mixer.

II Fixed Bowl Mixer. Chris explained the capacity of the SP 75 II was “exactly what was needed.” It allowed them to do smaller capacity batches as needed, while still having the ability of doing larger batches.

Mixing times turned out to be a pleasant surprise for Chris. Our mixing times have dramatically decreased, reported Chris. Chris went on to explain that the batches are mixed much more gently in less amount of time, creating a

higher quality end product (*pictured below*) and increasing productivity. With the time saved, his baker has more time to work on other projects.

Chris is very happy with his new mixer and the products that are coming from it. “I would choose Kemper again because of the excellent service we received despite being in the middle of the Pacific Ocean.”

—Shawna Goldfarb



Mauna Kea sourdough fresh from the oven.